

Powered by



XTV12850 ▶ 12V 85Ah

XTV 12850 is a general battery up to 12 years expected life in standby service or more than 260 cycles at 100% discharge in cycle service. XTV has a wider operating temperature range, which makes them more suitable for the systems in harsh conditions.



► Specification

Cells Per Unit	6
Voltage Per Unit	12
Capacity	85 Ah @ 10hr-rate to 1.80V per cell @25 °C (77°F)
Weight	Approx. 31.2 kg(68.78 lbs)
Maximum Discharge Current	800A(5sec)
Internal Resistance	Approx. 6.5mΩ
Operating Temperature Range	Discharge: -20 °C~50°C (-4°F~122°F) Charge: -20°C~50°C (-4°F~122°F) Storage: -15°C~40°C (5°F~104°F)
Nominal Operating Temperature Range	25°C±3°C(77°F±5°F)
Float Charging Voltage	13.5 to 13.8 VDC/unit Average at 25°C(77°F)
Recommended Maximum Charging Current Limit	25.5A
Equalization and Cycle Service	14.4 to 15.0 VDC/unit Average at 25°C(77°F)
Self Discharge	CSB Batteries can be stored for more than 6 months at 25°C(77°F). Please charge batteries before using. For higher temperatures the time interval will be shorter.
Terminal	I2-Thread lead alloy recessed terminal to accept M6/M8 bolt
Container Material	PP (UL 94-V0/File E50955)*Flammability resistance of (UL 94-HB/File E216959) can be available upon request.



CSB-manufactured VRLA batteries are UL-recognized components under UL924 and UL1989.

CSB is also certified by ISO 9001 and ISO 14001.

Dimensions :	Overall Height (H)	Container height (h)	Length (L)	Width (W)
Unit: mm (inch)	217.6±2.5 (8.57±0.1)	214.6±2.5 (8.45±0.1)	343±2.5 (13.5±0.1)	170±2 (6.69±0.08)

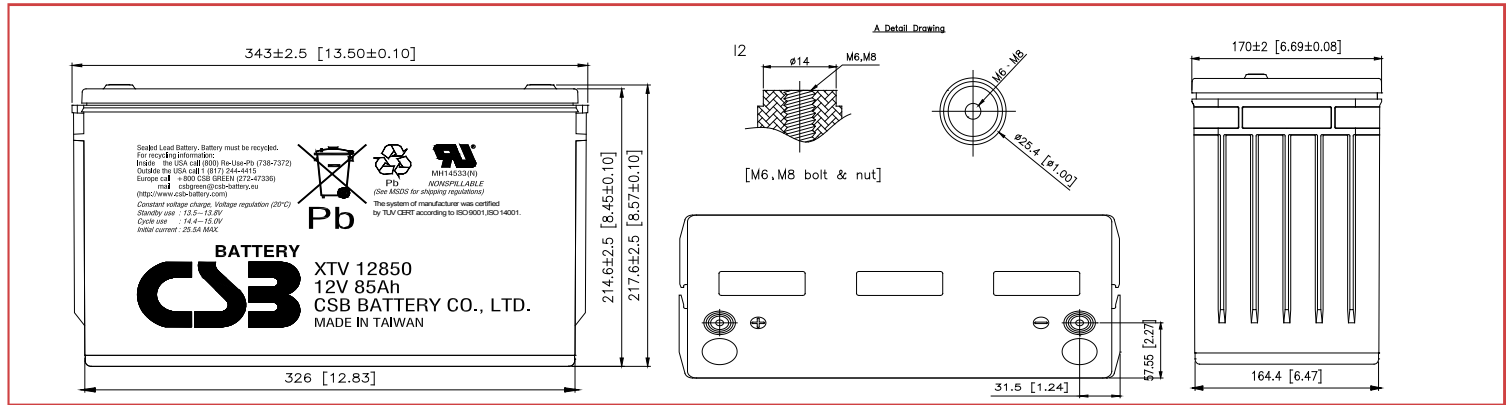

Constant Current Discharge Characteristics Unit:A (25°C, 77°F)

F.V/Time	5MIN	10MIN	15MIN	30MIN	1HR	2HR	3HR	4HR	5HR	8HR	10HR	20HR
1.60V	323	224	170	103	62.0	36.8	25.3	19.4	16.1	10.7	8.90	4.64
1.67V	286	209	163	101	60.6	36.0	25.1	19.3	15.9	10.6	8.80	4.61
1.70V	266	200	159	99.4	59.9	35.7	24.8	19.1	15.8	10.5	8.78	4.59
1.75V	236	185	151	95.6	58.3	34.6	24.1	18.7	15.6	10.3	8.58	4.54
1.80V	215	166	139	90.1	56.1	33.2	23.6	18.5	15.3	10.2	8.50	4.46
1.85V	178	148	121	82.7	52.3	31.0	22.4	17.5	14.5	9.85	8.10	4.28

Constant Power Discharge Characteristics Unit:W (25°C, 77°F)

F.V/Time	5MIN	10MIN	15MIN	30MIN	1HR	2HR	3HR	4HR	5HR	8HR	10HR	20HR
1.60V	3027	2260	1819	1125	687	409	290	227	187	125	104	54.3
1.67V	2800	2148	1765	1113	678	404	287	224	185	124	103	53.7
1.70V	2704	2085	1745	1102	676	401	285	223	183	123	102	53.4
1.75V	2536	1956	1636	1068	662	391	278	219	182	122	101	53.2
1.80V	2234	1816	1499	1017	638	376	272	213	178	120	100	52.4
1.85V	1901	1615	1320	945	601	356	259	203	169	116	96.6	50.8

Ratings are preliminary and subject to change.

Trickle (or Float) Service Life

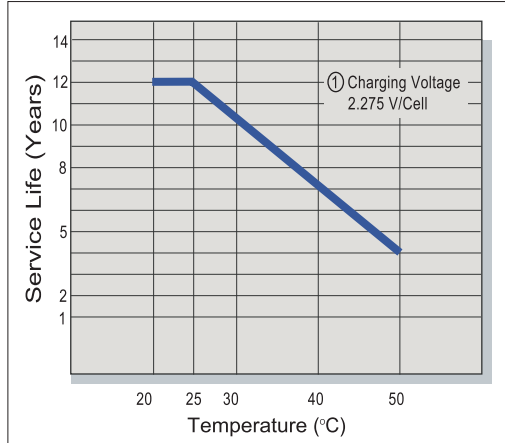

Capacity Retention Characteristic

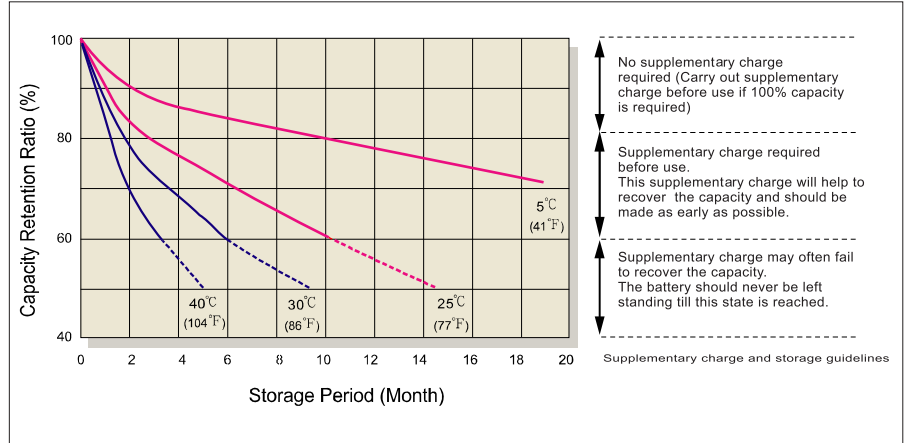

Battery Voltage and Charge Time for Standby Use

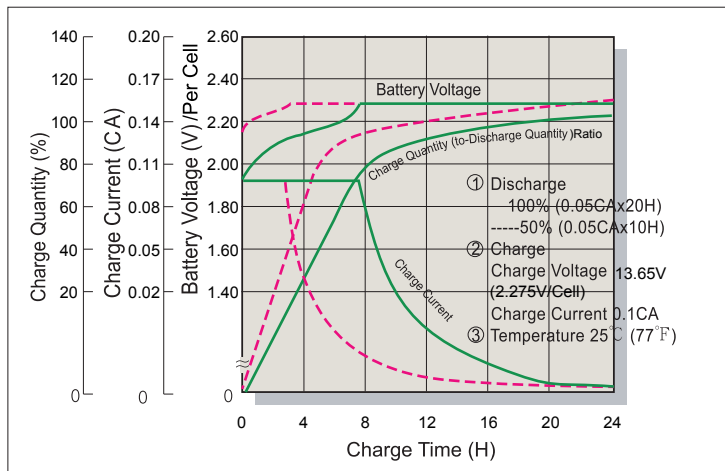

Series Cycle Service Life

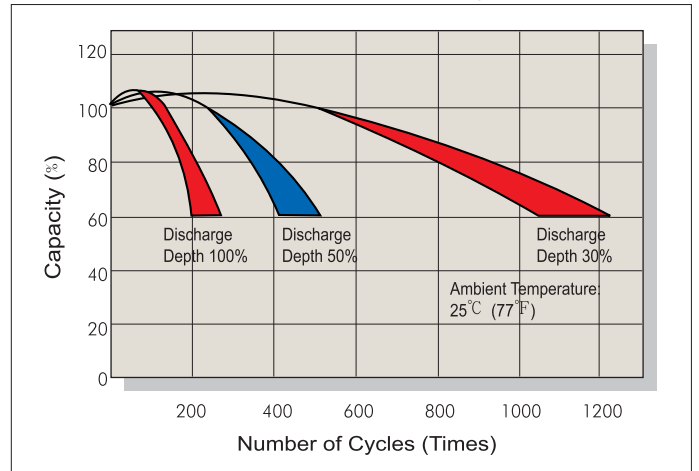

Battery Voltage and Charge Time for Cycle Use

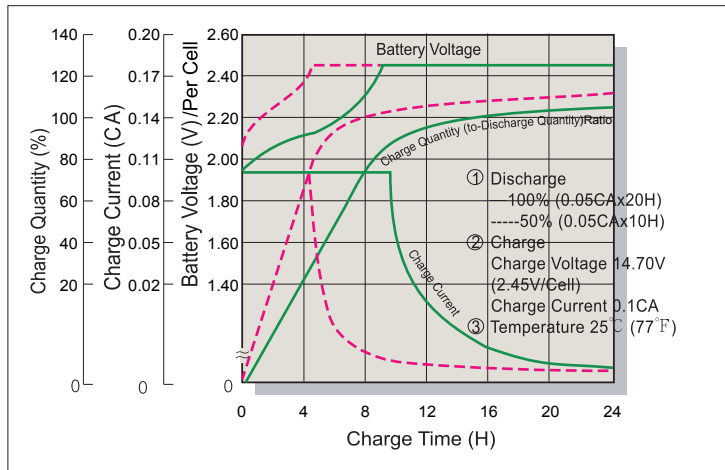

Terminal Voltage (V) and Discharge Time

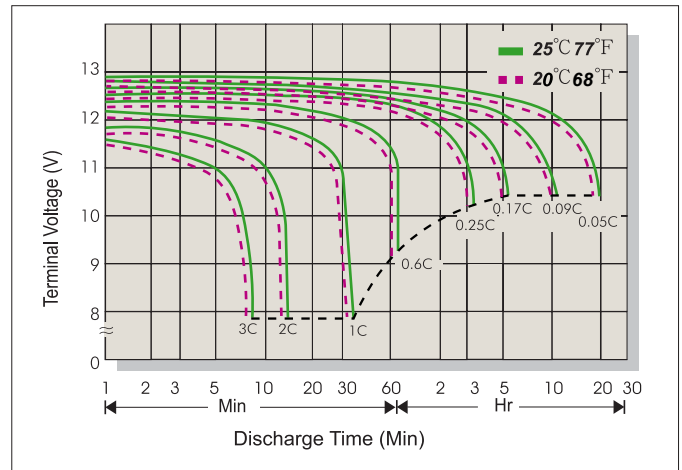

Charging Procedures

Application	Charge Voltage(V/Cell)			Max. Charge Current
	Temperature	Set Point	Allowable Range	
Cycle Use	25°C (77°F)	2.45	2.40~2.50	0.3C
Standby	25°C (77°F)	2.275	2.25~2.30	

Discharge Current VS. Discharge Voltage

Final Discharge Voltage V/Cell	1.75	1.70	1.60	1.30
Discharge Current(A)	0.2C>(A)	0.2C<(A)<0.5C	0.5C<(A)<1.0C	(A)>1.0C

Sales Office URL: WWW.CSB-BATTERY.COM

GLOBAL HQ
CSB BATTERY CO., LTD. (TAIWAN)
 Tel : +886-2-2555-5600
 Fax : +886-2-2555-3300
 mail : service@csb-battery.com.tw

BEIJING OFFICE. (CHINA)
CSB BATTERY TECHNOLOGIES (BEIJING) CO., LTD.
 Tel : +86-10-59621300/1301/1302/1303
 Fax : +86-10-59621304
 mail : chinasl@csb-battery.com

AMERICA HQ
CSB BATTERY TECHNOLOGIES INC. (U.S.A)
 Tel : +1-817-244-7777/1-(800)3-CSB-USA(272872)
 Fax : +1-817-244-4445
 mail : csb@csb-battery.com

SHANGHAI OFFICE. (CHINA)
CSB BATTERY LOGISTIC (SHANGHAI) CO., LTD.
 Tel : +86-21-5046-1622/5046-0833
 Fax : +86-21-5064-3314
 mail : chinasl@csb-battery.com

EUROPE HQ
CSB Battery Europe BV.
 Tel : +31(0)-180-418-140
 Fax : +31(0)-180-418-327
 mail : eurosales@csb-battery.eu

SHENZHEN OFFICE. (CHINA)
CSB BATTERY LOGISTIC (SHANGHAI) CO., LTD.
 Tel : +86-755-8831-6488/6396/6356
 Fax : +86-755-8831-6548
 mail : she@csb-battery.com.cn