

Powered by



XTV12750 ▶ 12V 75Ah

XTV 12750 is a general battery up to 12 years expected life in standby service or more than 260 cycles at 100% discharge in cycle service. XTV has a wider operating temperature range, which makes them more suitable for the systems in harsh conditions.



► Specification

Cells Per Unit	6
Voltage Per Unit	12
Capacity	75 Ah @ 10hr-rate to 1.80 V per cell @25 °C (77°F)
Weight	Approx. 29.5 kg(65.04 lbs)
Maximum Discharge Current	800A(5sec)
Internal Resistance	Approx. 6.5mΩ
Operating Temperature Range	Discharge: -20 °C~50°C (-4°F~122°F) Charge: -20°C~50°C (-4°F~122°F) Storage: -15°C~40°C (5°F~104°F)
Nominal Operating Temperature Range	25°C±3°C (77°F±5°F)
Float Charging Voltage	13.5 to 13.8 VDC/unit Average at 25°C(77°F)
Recommended Maximum Charging Current Limit	22.5A
Equalization and Cycle Service	14.4 to 15.0 VDC/unit Average at 25°C(77°F)
Self Discharge	CSB Batteries can be stored for more than 6 months at 25°C (77°F). Please charge batteries before using. For higher temperatures the time interval will be shorter.
Terminal	I2-Thread lead alloy recessed terminal to accept M6/M8 bolt
Container Material	PP (UL 94-V0/File E50955)*Flammability resistance of (UL 94-HB/File E216959) can be available upon request.



CSB-manufactured VRLA batteries are UL-recognized components under UL924 and UL1989.

CSB is also certified by ISO 9001 and ISO 14001.

► Dimensions :

Unit: mm (inch)

Overall Height (H)	Container height (h)	Length (L)	Width (W)
214.3±2.5 (8.44±0.1)	211.3±2.5 (8.32±0.1)	308.7±2.5 (12.15±0.1)	169±2 (6.66±0.08)

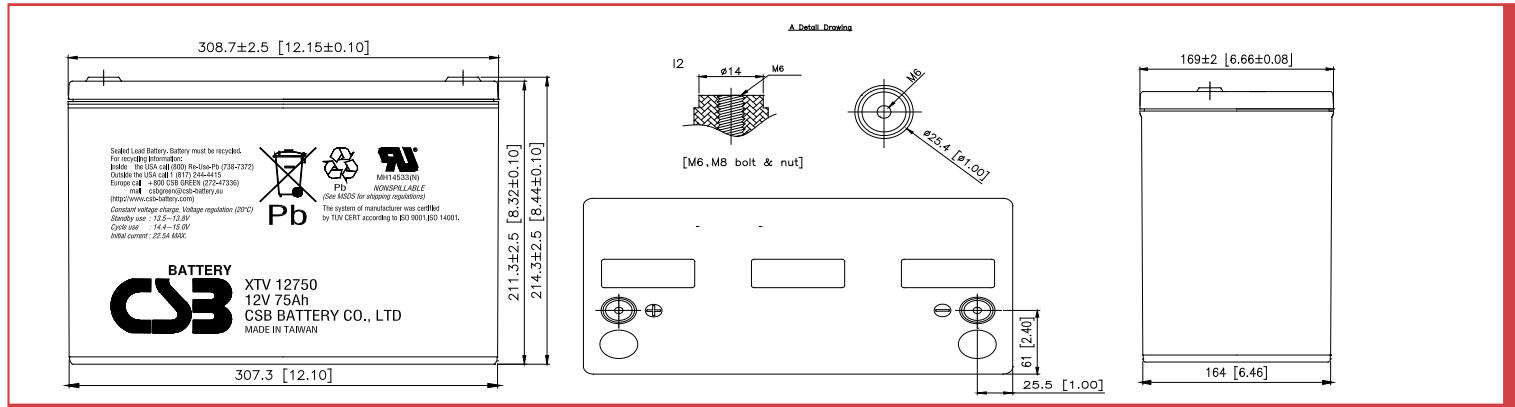

Constant Current Discharge Characteristics Unit:A (25°C, 77°F)

F.V/Time	5MIN	10MIN	15MIN	30MIN	1HR	2HR	3HR	4HR	5HR	8HR	10HR	20HR
1.60V	285	197	151	91.6	54.6	32.4	22.3	17.1	14.1	9.39	7.89	4.09
1.67V	252	184	144	90.0	53.5	31.7	22.1	17.0	14.0	9.35	7.73	4.07
1.70V	235	176	140	88.4	52.9	31.5	21.8	16.9	13.9	9.32	7.67	4.05
1.75V	208	163	133	84.5	51.4	30.6	21.2	16.6	13.7	9.16	7.57	4.00
1.80V	189	147	123	79.7	49.5	29.2	20.8	16.3	13.4	9.00	7.50	3.93
1.85V	156	131	107	72.9	46.2	27.4	19.7	15.4	12.9	8.68	7.14	3.78

Constant Power Discharge Characteristics Unit:W (25°C, 77°F)

F.V/Time	5MIN	10MIN	15MIN	30MIN	1HR	2HR	3HR	4HR	5HR	8HR	10HR	20HR
1.60V	2671	1993	1604	993	606	361	256	201	165	111	92.4	47.9
1.67V	2469	1895	1557	982	598	356	253	197	163	110	91.6	47.4
1.70V	2385	1839	1539	973	596	354	251	195	162	109	90.8	47.1
1.75V	2237	1726	1444	942	583	345	245	193	161	107	90.0	46.9
1.80V	1971	1602	1322	898	563	331	240	188	156	106	89.2	46.2
1.85V	1677	1424	1165	834	531	314	228	178	149	102	85.3	44.8

Ratings are preliminary and subject to change.

Trickle (or Float) Service Life

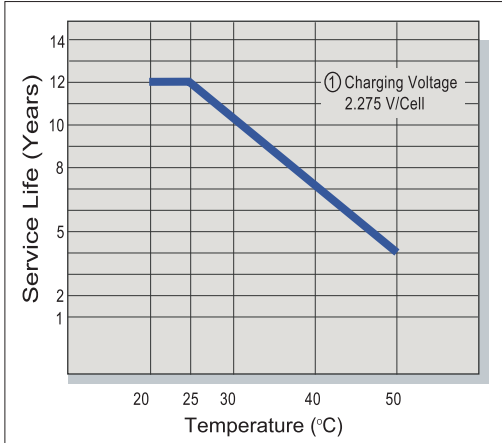

Capacity Retention Characteristic

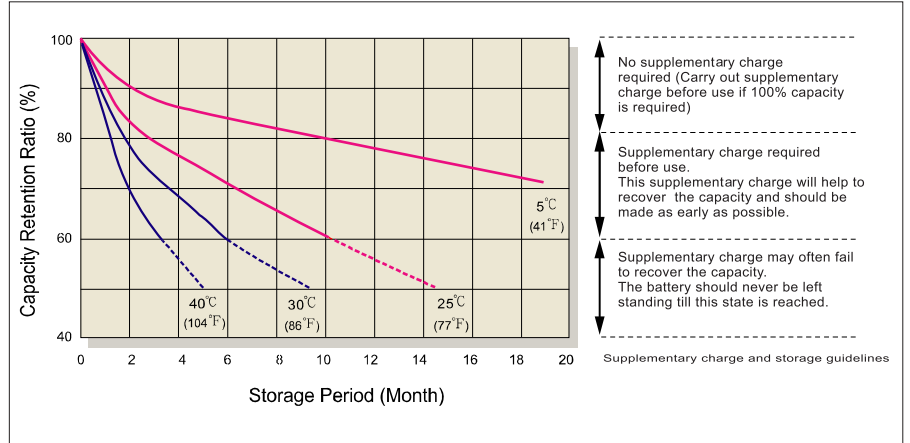

Supplementary charge and storage guidelines

- No supplementary charge required (Carry out supplementary charge before use if 100% capacity is required)
- Supplementary charge required before use. This supplementary charge will help to recover the capacity and should be made as early as possible.
- Supplementary charge may often fail to recover the capacity. The battery should never be left standing till this state is reached.

Battery Voltage and Charge Time for Standby Use

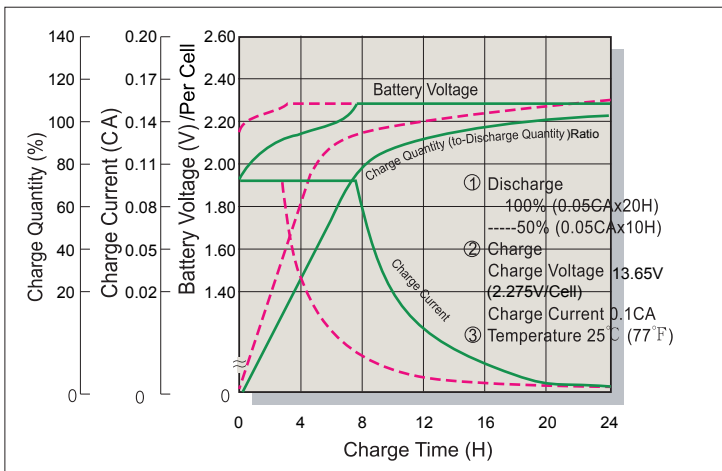

Series Cycle Service Life

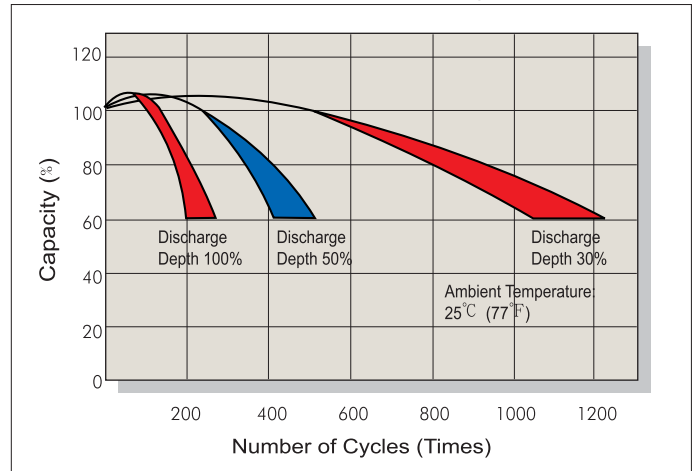

Battery Voltage and Charge Time for Cycle Use

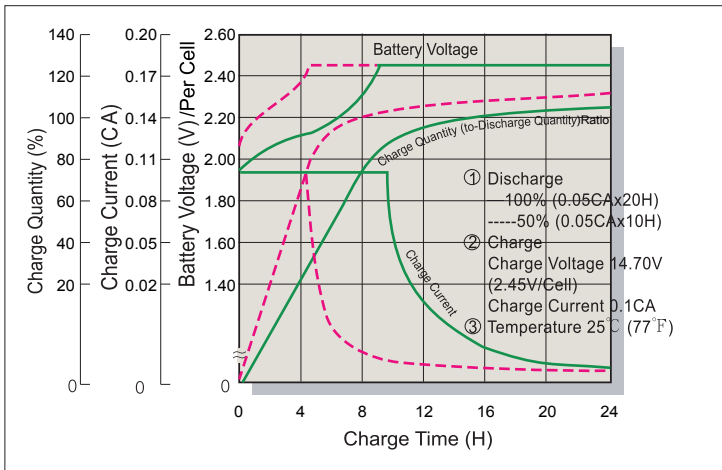

Terminal Voltage (V) and Discharge Time

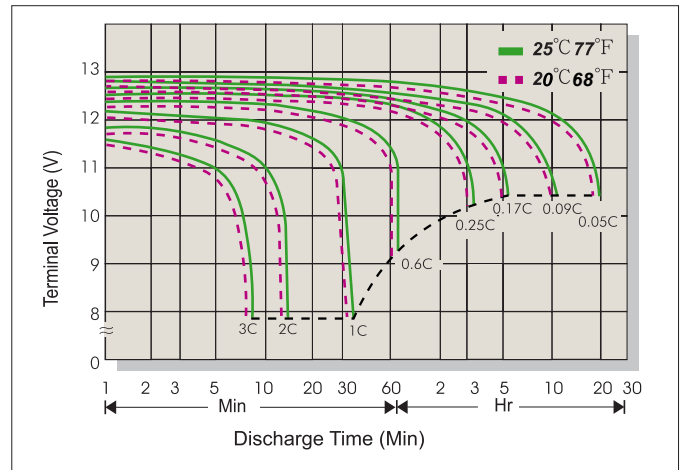

Charging Procedures

Application	Charge Voltage(V/Cell)			Max. Charge Current
	Temperature	Set Point	Allowable Range	
Cycle Use	25°C(77°F)	2.45	2.40~2.50	0.3C
Standby	25°C(77°F)	2.275	2.25~2.30	

Discharge Current VS. Discharge Voltage

Final Discharge Voltage V/Cell	1.75	1.70	1.60	1.30
Discharge Current(A)	0.2C>(A)	0.2C<(A)<0.5C	0.5C<(A)<1.0C	(A)>1.0C

Sales Office URL: WWW.CSB-BATTERY.COM

GLOBAL HQ
CSB BATTERY CO., LTD. (TAIWAN)
 Tel : +886-2-2555-5600
 Fax : +886-2-2555-3300
 mail : service@csb-battery.com.tw

BEIJING OFFICE. (CHINA)
CSB BATTERY TECHNOLOGIES (BEIJING) CO., LTD.
 Tel : +86-10-59621300/1301/1302/1303
 Fax : +86-10-59621304
 mail : chinasl@csb-battery.com

AMERICA HQ
CSB BATTERY TECHNOLOGIES INC. (U.S.A)
 Tel : +1-817-244-7777/1-(800)3-CSB-USA(272872)
 Fax : +1-817-244-4445
 mail : csb@csb-battery.com

SHANGHAI OFFICE. (CHINA)
CSB BATTERY LOGISTIC (SHANGHAI) CO., LTD.
 Tel : +86-21-5046-1622/5046-0833
 Fax : +86-21-5064-3314
 mail : chinasl@csb-battery.com

EUROPE HQ
CSB Battery Europe BV.
 Tel : +31(0)-180-418-140
 Fax : +31(0)-180-418-327
 mail : eurosales@csb-battery.eu

SHENZHEN OFFICE. (CHINA)
CSB BATTERY LOGISTIC (SHANGHAI) CO., LTD.
 Tel : +86-755-8831-6488/6396/6356
 Fax : +86-755-8831-6548
 mail : she@csb-battery.com.cn